

## Lithium ion batteries balancing

Daniel Chatroux

► **To cite this version:**

Daniel Chatroux. Lithium ion batteries balancing. PCIM 2014 - Power Conversion and Intelligent Motion Europe, May 2014, Nuremberg, Germany. cea-03292974

**HAL Id: cea-03292974**

**<https://hal-cea.archives-ouvertes.fr/cea-03292974>**

Submitted on 20 Jul 2021

**HAL** is a multi-disciplinary open access archive for the deposit and dissemination of scientific research documents, whether they are published or not. The documents may come from teaching and research institutions in France or abroad, or from public or private research centers.

L'archive ouverte pluridisciplinaire **HAL**, est destinée au dépôt et à la diffusion de documents scientifiques de niveau recherche, publiés ou non, émanant des établissements d'enseignement et de recherche français ou étrangers, des laboratoires publics ou privés.

# Lithium ion batteries balancing

Daniel Chatroux, CEA, France, daniel.chatroux@cea.fr

The Power Point Presentation will be available after the conference

## Abstract

Standard aqueous batteries need no balancing electronic circuit. Balancing circuit is a specific need for lithium ion batteries. The first goal of this presentation is to compare the technologies differences between aqueous batteries and Lithium ion to explain the advantages and disadvantages about current losses in storage and for balancing circuit specifications.

The second goal is to describe some passive and active, dissipative or not balancing circuits.

## 1. Context

The CEA (Commissariat à l'Energie Atomique et aux Energies Alternatives) is an energy research center in France dedicated to research and development in nuclear applications and in renewable energies. Two of the main research fields of LITEN Institute, part of CEA in Grenoble, are fuel cells and lithium batteries (from components to systems).

The LITEN masters the whole lithium-ion batteries production line: materials for Lithium ion accumulators, accumulator conception, production, battery packs design, battery management systems conception, electric vehicle integration and monitoring of vehicles.

In different project, we replace existing Lead acid, NiCd or NimH battery packs by Lithium ion batteries. Unlike lead acid batteries, NiCd or NimH ones who don't need any electronic balancing circuit, each Lithium ion accumulator needs a voltage monitoring and a balancing circuit in order to provide safety and long term reliability of the batteries.

## 2. Differences between aqueous and lithium ion technologies

### 2.1. Aqueous batteries

The three main aqueous technologies (lead acid, NiCd and NimH) have a lot of parasitic electrochemical reactions in parallel with the main one. These parasitic reactions have different electrochemical potentials, and so have different chemical kinetics depending of the accumulator voltage.

**One first impact of these parasitic reactions is self-discharge phenomenon.**

At nominal voltage, these parasitic reactions are still active. It's a consumption of energy with a discharge rate of some weeks or months. This is a disadvantage.

**The second impact is intrinsic voltage clamping at the end of the charge.**

For example, at the end of the charge for a lead acid battery, the main electrochemical reaction is finished, so the voltage drops up to the water dissociation voltage. If the charge goes on, the current generates heat and gas from the water dissociation but the voltage stay the same: it's the voltage clamping behavior of the accumulator cell which can be simulated by a "zener diode", as in the figure 1.

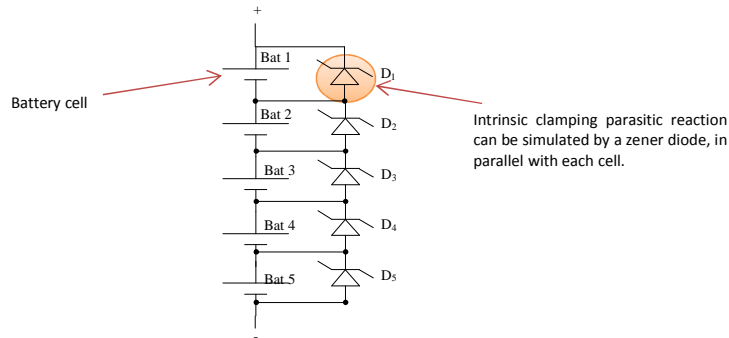

Figure 1: parasitic reactions simulation in aqueous batteries technologies

This parasitic reaction is an advantage: when charging multiple cells connected in series (= a battery), as all cells are not identical and in the same state of charge, a cell will end its charge first. As other cells are not fully charged, the current is maintained to charge these cells. The first cell stays fully charged and produce heat and water dissociation: it's a natural balancing that allows the end of charge for other cells.

**Thanks to the parasitic reaction, there is an intrinsic voltage clamping with the possibility to balance the different accumulators in series only by the prolongation of the charging phase.**

However, balancing phase duration has to be minimized because of its great impact on battery life time and charge efficiency.

## 2.2. Lithium ions batteries

The composition of Lithium ion accumulator is for standard design: a copper foil with graphite layers (the two faces) for the negative electrode, a separator with electrolyte impregnation, a positive electrode with aluminum foil and layers of a positive active material. The electrochemical reaction is based on Lithium ion insertion (intercalation) in graphite or in positive active material for charge and discharge. The reaction mechanism of lithium-ion batteries is presented in the Figure 2. The positive and negative materials usually have a layered structure to facilitate lithium ions insertion. The main effect of the charge and discharge reaction is the back and forth movement of lithium ions between the electrodes, matched by a corresponding flow of electrons in the external circuit.

This electrochemical process is sometimes called a **“rocking-chair” mechanism**.

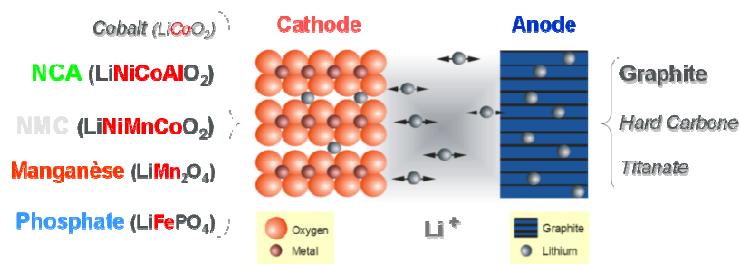

Li-Ion picture: courtesy of Prof. H. Winter



Figure 2: Lithium ion technologies

The Lithium ion electrochemistry is a dry one.

Because water is a pollutant in this chemistry, the accumulators are built in dry room.

Except long term ageing, there is no parasitic reaction, so:

- ⇒ No discharge current
  - Good quality Lithium ion accumulator stores energy for years. It's a great advantage in the application to get the battery charged.
- ⇒ No intrinsic voltage clamping reaction
  - There is no natural balancing, and an external balancing circuit is added when accumulators are connected in series

### 2.3. Comparison

The faradic efficiency is the ratio between the charge extracted from the battery in discharge compared and the charge injected.

For aqueous battery, the faradic efficiency is about 90% because of the loss of electrons in parasitic reaction and in the overcharge during the balancing phase.

**For Lithium accumulator, the Faradic efficiency is near 100%.**

The energy efficiency takes into account the faradic efficiency and the energy losses in the serial resistance: it's the reason why the energy efficiency is directly linked with the levels of charge and discharge currents.

**For lithium accumulator, energy efficiency is higher than 90%** (95% for example), typically 10 to 20% higher than aqueous ones.

### 3. Usefulness of a balancing circuit

With perfect Lithium ion accumulators in series, there is no need of balancing circuit, but:

In reality, there are residual parasitic phenomena:

- ⇒ Dispersion of leakage current, simulated by a parallel resistance,
- ⇒ Faradic efficiency less than 100%, with some dispersion,
- ⇒ Discharge by external leakage current due to moisture or voltage measurement electronic circuit

These parasitic phenomena depend on the technology and the manufacturing quality of the accumulators. For example, water pollution creates some leakage current; accumulator ageing has an impact on Faradic efficiency.

Because of the difference of discharge by the parasitic elements, after a long time or a succession of charges and discharges, the different accumulators in series don't have exactly the same energy stored so it's necessary to have a balancing circuit to compensate.

**Good quality accumulators are nearly perfect**, so it's not necessary to balance after each charge. For example, after a fast charge, the unbalance is about 0.4%, so the impact on the range of electric car designed for 100 km is only 400 m. **But because it's a cumulative phenomenon, it's necessary to balance regularly.**

### 4. Balancing circuit with Zener diode for LiFePO<sub>4</sub> batteries

A first solution is to copy the intrinsic clamping circuit in aqueous electro-chemistries: adding zener diode in parallel of each cell to have balancing by a clamping circuit (Figure 1).

For most technologies of Lithium ion batteries, this solution doesn't work because of the precision needed. For Lithium ion accumulators based on Cobalt or manganese oxide, the end of charge voltage is 4.2V, very close to the 4.5V maximum voltage. An overvoltage can

cause catastrophic failure with a risk of fire and explosion. The 5% precision of zeners are not adapted for these chemistries.

The other problem of Zener diodes is leakage current for low voltage ones.

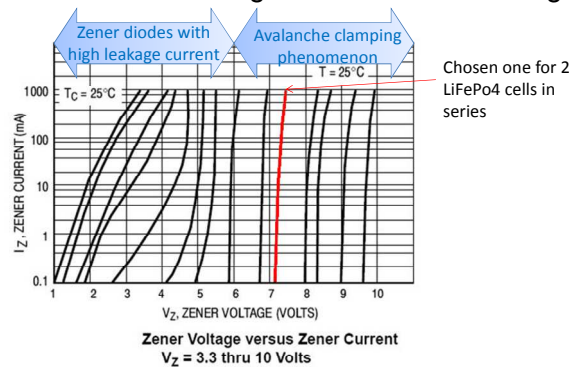

Figure 3: voltage versus current of different zener diodes

For zener diodes of 6V or more, the physical phenomenon is avalanche clamping, not zener effect. The leakage current under the clamping voltage is very low. After the specified voltage, clamping is effective with a low serial resistance: curves are almost vertical in Figure 3.

Below six volts, the physical phenomenon is zener effect. The depleted zone is very thin. Quantic effects are active, so an electron but without the energy level has some probability to cross the potential barrier. The leakage current is high, clamping is very soft. Zener diodes below 6 volts aren't good clamping components.

For Lithium phosphate accumulators based on iron phosphate (LiFePO<sub>4</sub>), the end of charge voltage is 3.6V for the same maximum voltage of 4.5V. Because of this high voltage safety margin, zener diode tolerances may be accepted.

For some specific applications we used LiFePO<sub>4</sub> batteries with 7.5V Zener clamping for each two accumulators in series.

## 5. Dissipative active balancing circuits

The main advantage of a zener clamping circuit is the simplicity and the price, but there is no reporting of cells voltages data. For safety and long life performances, a voltage monitoring of the cells, not to overcharge or over-discharge, the accumulators is essential. Main balancing circuits are based on a voltage monitoring circuit on each cells and an electronic switch in series with a resistance to dissipate the current if necessary. At the end of the charge, it's possible to discharge the highest voltage cells to balance all the cells at the same voltage, so the same state of charge.

For a power electronic engineer point of view, this dissipative solution seems to be a waste of energy, but because **unbalancing is a slow phenomenon with very low energy involved**, this solution is suited for good quality accumulators.

For 400V 40Ah commercial batteries, the levels of discharge currents are from 250mA (CEA) to some tens of mA (automotive). The very low current for balancing allows having all the balancing circuits on only one PCB for cost minimization.

An example of dissipative solution is the LTC6802 from Linear Technology [1].

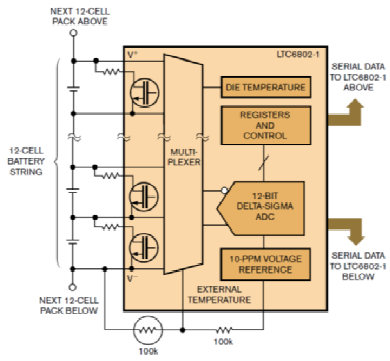

Figure 4: LTC6802

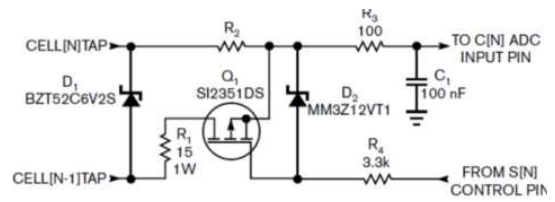

Figure 5: External MOSFET for 250 mA discharge current

This circuit can measure the voltage of up to 12 cells in series. This information is transmitted by a daisy chain up to a microcontroller. At the end of the charge, the cells with highest voltages are discharged by the resistance driven by a MOSFET, up to the lower voltage of all the accumulators.

Internal MOSFET of the LTC6802 can hold a discharge of 10 mA. Higher current need external additional MOSFET.

In our laboratory, the main balancing circuits are designed with LTC6802. For state of charge calculation with very good precision a current measurement by shunt is used.



Figure 6: shunt and central microcontroller

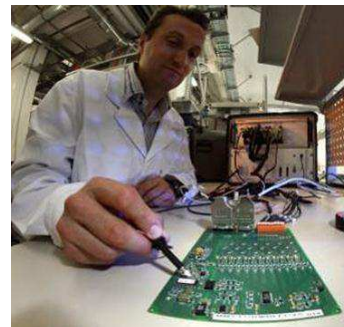

Figure 7: balancing card for battery module

Because of the low power dimensioning, balancing circuit are not suited for initial balancing after battery manufacture. To minimize the initial unbalancing, the accumulator has to be at the same state of charge. This point is not a problem and don't have any additional cost.

In battery manufacturing, accumulators are built, electrolyte is added, and the final step is a succession of charge and discharge for accumulator forming. This last step is necessary to provide the performances and to create passivation on graphite on negative electrode. To have the same state of charge, the manufacturer has only to stop the last cycle at the same level. A state of charge between 20% and 80% is suited for shipping and storage for a long time with low lifetime impact. Best manufacturer can produce accumulators with the same state of charge at the production line output and with a low self-discharge, so shipping and storage have low impact. In this case, initial unbalancing may be compensated only by the internal balancing circuit without previous recharge of the accumulator or high power external balancing circuit.

## 6. Non dissipative active balancing circuit

Non dissipative active balancing circuits have an interest only if they add a low overcost. That's the line we follow to develop a solution with only some bulky central components and some low cost CMS ones for each accumulator stages in series [2].

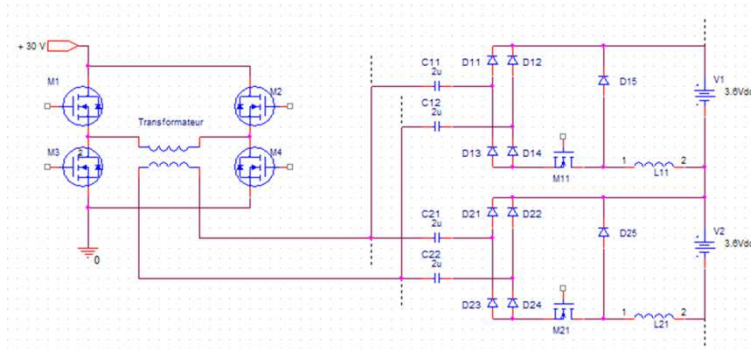

Figure 8: low cost non dissipative balancing circuit

Accumulators are voltage sources. A standard design will required a PWM control circuit per accumulator stage in series to regulate the current of each stage.

Our design is based on a dimensioning of **converter in a discontinuous mode to control the current** at the desired level for all the battery voltage range.

The inverter provides pulse with low duty cycle, for example 10% with pulses of  $1\mu\text{s}$ .

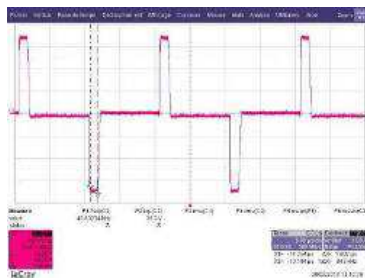

Figure 9: inverter voltage

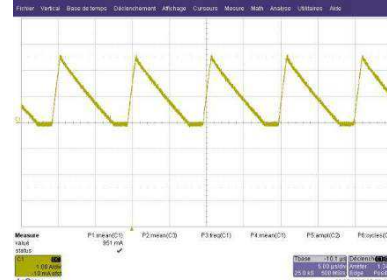

Figure 10: inductance current

Because of insulation issues, pulses are transmitted by a transformer. The transformer outputs transmit the pulses to each stage by low voltage film capacitors (C11, C12 on Figure 8). After rectification (D11-D14), pulses are applied to an inductance (L11) and free-wheeling diode (D15) as at a buck structure.

The MOSFET (M11) is not for PWM regulation: it acts as a switch to connect the output to the accumulator (V1) or not.

Accumulator voltage range is limited by end of charge voltage and minimum voltage. For example, a LiFePO<sub>4</sub> accumulator has a minimum voltage of 2V, a flat plateau at 3.3V from 10% to 90% of state of charge, and a maximum voltage of 3.6V at the end of the charge.

Knowing this voltage variation, it's possible to choose the duty cycle and the dimensioning to keep the circuit in discontinuous mode, in order to have each output act as a current source.

To carry out this solution, we drive the MOSFET by the LTC6802, as a dissipative circuit with the adapted strategy.

At the end of the charge, the LTC6802 balancing algorithm stop the charge of the accumulators by the charger, and accumulators which are not fully charged are finished to charge by the active non-dissipative balancing circuit, by closing the MOSFET of the accumulator stage.

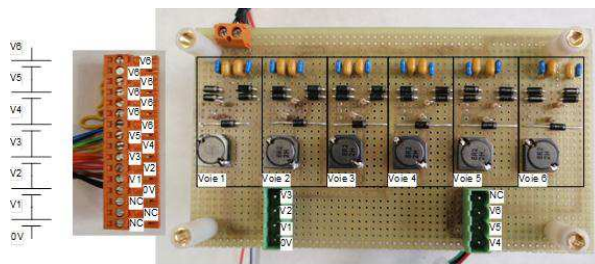

Figure 11: six outputs

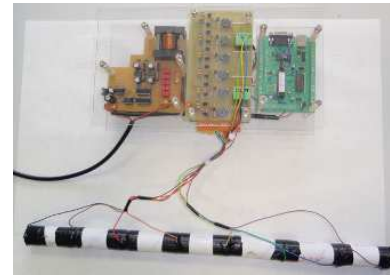

Figure 12: balancing circuit and control in test

The Figure 13 shows the charge of 6 cells in series with different initial state of charge.

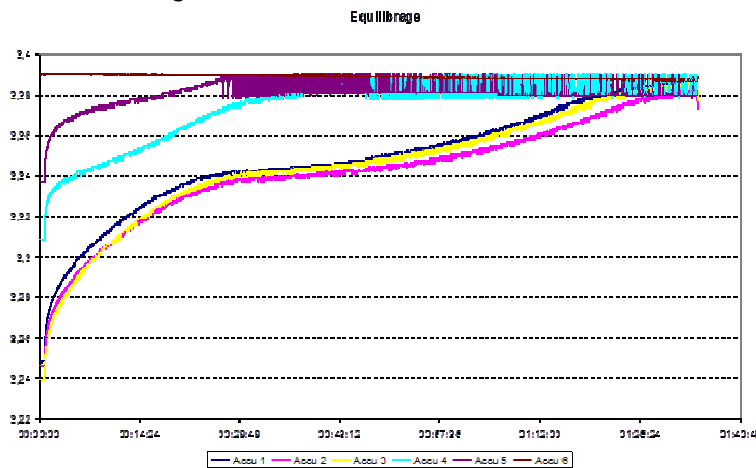

Figure 13: end of charge voltages

Cell 5 is fully charged after about 25 minutes, and begins to balance.

At the end of charge, the voltages dispersion is limited at 14 mV.

## 7. Compensation circuit of capacitance dispersion

The balancing circuit function is to compensate the difference of state of charge between cells in series in a battery. The energy involved is low and we have time to do this operation.

**The goal of a non-dissipative balancing circuit is to compensate the unbalance of state of charge and not to compensate the difference of capacity between the accumulators in series.**

The capacity of accumulators in series is the one which has the lowest value of capacity. So in the end of a discharge, there is some remaining energy in the accumulators with the biggest capacities. To optimize this situation, a good solution seems to be to exchange energy between the accumulators in the discharge phase. The design of the circuit may be the same as balancing ones but with ten times more current for example. In practice, the cost and space of the power electronic for the compensation of the differences of capacity is often prohibitive. The dispersion of capacity decreases when production volume rises up. So at level of quality of production, capacity compensation becomes not necessary.



It's very important to precise the two different cases of capacity difference compensation and balancing circuit because of the classic confusion between the two different problems with great difference of dimensioning and cost.

## **8. Conclusion**

Classic aqueous electrochemical accumulators have parasitic reactions with the disadvantage of self-discharge in some weeks or months, and the advantage of doing natural balancing of accumulators in series only by a phase of overcharge.

Lithium-ion accumulators have no parasitic electrochemical reaction, so self-discharge may be very low and the battery offer the possibility to keep the battery charged for years. The disadvantages are the needs to have a balancing circuit. Zener solution provides voltage balancing but only for Lithium ion technology with voltage safety margin as LiFePO<sub>4</sub>.

Active dissipative balancing circuits are adapted for all the Lithium ion technologies, for example the LTC6802 circuit.

An active non dissipative circuit optimized for a low over-cost compared with dissipative solution is proposed. The design is based on inductance in discontinuous mode for all the accumulator voltage range, to control the currents of all the outputs without a control circuit per accumulator stages.

## **9. References:**

[1] "Managing high-voltage lithium-ion batteries in HEVs" Michael Kultgen Linear Technology Corporation, EDN April 9, 2009

[2] « Charge Equalization system for batteries » Patent WO 2011/095610 A2